

The BayNavTech™ Signal Experimentation Facility (BaySEF™) is ready for use

M. Soellner, C. Briechle, G. Hechenblaikner, M. Kaindl, R. Kohl, M. Middendorf, W. Lindemer, C. Zecha,
EADS Astrium Germany, Ottobrunn

BIOGRAPHY

Dr. Matthias Soellner is navigation system engineer at EADS Astrium. He studied physics at the Technical University of Munich. Since 2000, he works at EADS-Astrium on satellite navigation with focus on navigation end-to-end signal performance, signal design and application experiments.

C. Briechle, G. Hechenblaikner, M. Kaindl, R. Kohl, M. Middendorf, W. Lindemer and C. Zecha are navigation system engineers at EADS Astrium.

ABSTRACT

The BayNavTech™ Signal Experimentation Facility (BaySEF™), currently built up by EADS Astrium, can be characterized shortly as a flexible high performance (real-time and offline) navigation receiver and evaluation platform for the analysis of signal performance of measured satellite navigation signals, typically from GIOVE, Galileo¹, present and modernized GPS etc. This paper presents the BaySEF™ architecture and design, key performance parameters, typical applications and some results from GIOVE-A and GPS C/A measurements.

INTRODUCTION

Since last year, the first Galileo test-satellite GIOVE-A transmits navigation signals from space. First receivers exist which are able to receive and process these navigation signals. In contrast to the BPSK 1 type open GPS-signals, these signals are of type BOC(1,1) in L1, BPSK 5 in E6 and AltBOC(15,10) in E5. Also GPS started already to expand the variety of transmitted signals with L2C. Moreover, additional systems like GLONASS, Compass and QZSS will provide further different types of navigation signals. Especially but not only in the initial transmission phases, these new signal-types need to be analysed also far beyond the normal receiver operation. A first question deals with the tracking behaviour in real-world atmospheric and local environments in dependency of the receiver parameters like bandwidth, dis-

criminators, etc. Moreover with these new signals also a plurality of different tracking modes and combinations is possible, which needs to be analysed for its practical advantages and disadvantages with respect to certain application driven boundary conditions. And what's about the transmission quality and stability? In order to enable investigations on such signal performance related questions for current and future navigation signals, EADS Astrium is currently building up the Bavarian Signal Experimentation Facility (BaySEF™) in Munich, which started now first investigations. It is one part of the BayNavTech™ Satellite Navigation Centre Munich. The second part is the Performance Assessment Facility (BayPAF™), a flexible development and analysis environment for the determination of the performance of system and application algorithms for navigation systems, application systems and services. Typical analysis examples are investigations on orbit-determination and time synchronisation or local integrity.

This paper focuses on the BaySEF, which can be shortly characterized as a flexible high performance (real-time and offline) navigation receiver and evaluation platform for the analysis of signal performance of measured satellite navigation signals, typically from GIOVE, Galileo, present and modernized GPS.

ARCHITECTURE

The architectural concept of the BaySEF is shown in Figure 1. The facility includes two equal receiver-and signal-processing sub-systems, which can be operated combined or separately. This is to allow for fixed and mobile experimentation including differential investigations.

As optional signal sources, active broad-band omniantennas, a 3m parabolic dish and navigation signal generators (Astrium NSG 5100) are available, but any other (e.g. high-gain-) antennas and IF- as well as RF-signal generators can be used additionally or instead.

¹ Galileo is a trademark of the European Commission and the space program Galileo is a joint initiative of the European Commission and the European Space Agency.

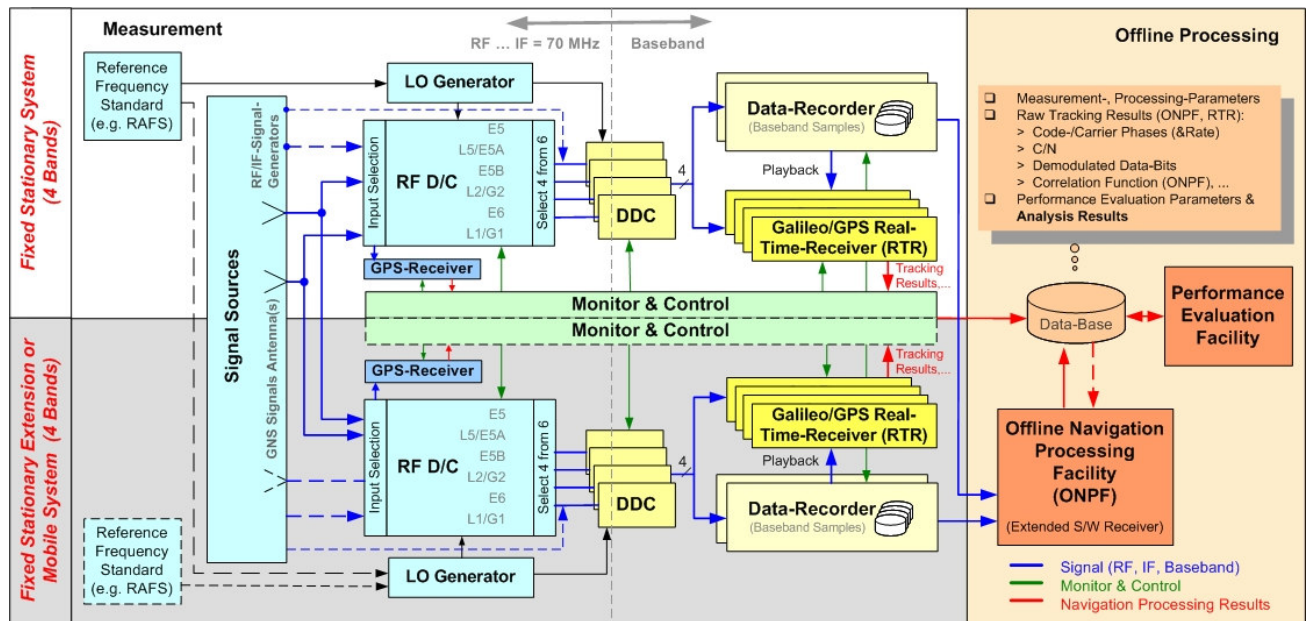

Figure 1 BaySEF Architectural Block-Diagram

Each of both systems is equipped with RF-Frontends for different frequency bands followed by DDCs for digitalisation and pre-processing. Corresponding output base-band samples can be recorded and in parallel sent to FPGA based Galileo/GPS receivers. Recorded files can be played back to the Galileo/GPS receivers and transferred to PCs for offline processing.

The measurement systems are completed with GPS reference receivers and uninterrupted power supply units (UPS). Monitoring and control (M&C) of the systems including all sub-devices is performed with dedicated software and user-friendly graphical user interfaces from a PC. Raw results of code-tracking (like C/N, code-/carrier phase and phase-rate, demodulated data-bits) from reference-receivers and Galileo/GPS receivers are stored for later evaluation on the performance aspects under consideration.

In Figure 2, one of the two BaySEF measurement system racks is shown. The upper part houses the analogue RF-Frontends with all the input and output signal interfaces, the GPS reference-receiver and the switch-matrix for Frontend selections. The sub-rack in the middle includes all the DDCs, GPS/Galileo FPGA based receiver cards, Data-recorders as well as an embedded PC. The grey ribbon-cables are for the signal sample transfer via front-panel-data-bus (FPDP). Just below the small placket, the flat unit is for DDC synchronisation. The lower part (with the all black devices) consists of the disc system for the data-recorder and the two UPS units at the bottom of the rack.

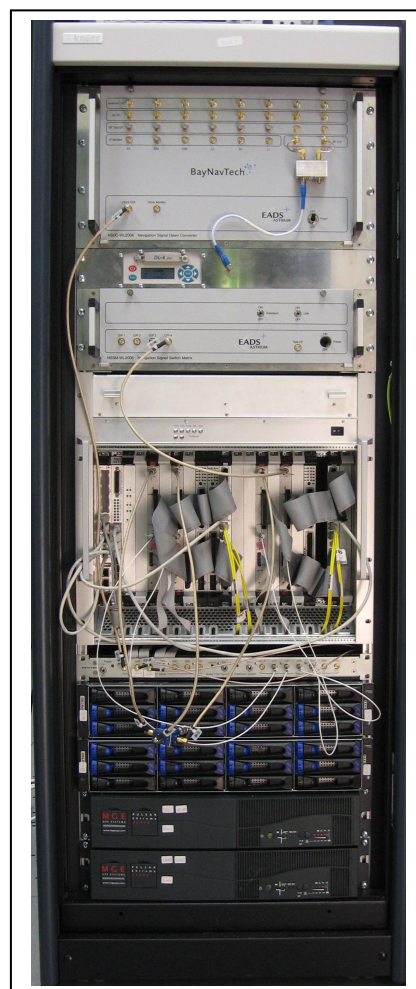

Figure 2 One of the two equal BaySEF measurement systems

MEASUREMENT SUB-DEVICES

In the following, the functional and performance characteristics of the individual BaySEF sub-devices are explained in more detail.

Signal sources

The BaySEF is currently equipped with three equivalent conical spiral antennas. Two of them are mounted on the roof of the EADS-Astrium building as shown in Figure 3, and the third is intended for mobile experimentation.

The wideband right circular polarised antennas provide a well omni-directional pattern of $\pm 80^\circ$ 3-dB beam-width. Together with wide-band filter and LNA, finally a bandwidth of 1050 – 1650 MHz and a noise-figure of 1.2 dB is obtained. As an alternative, also a parabolic dish of 3 m diameter is available for connection. This antenna with helix feed can be rotated per software on the full hemisphere to trace any satellite path.

Of course, the BaySEF can also be connected to other antennas like a high gain antenna with minor adaptations mainly for the input power-level.

In addition to the antenna-interface, also signal-generators for navigation signals (e.g. Astrium NSG 5100, Spirent) or interference simulation can be connected either to individual bands or commonly to all frequency bands. Interfaces for that are available at RF and IF. Therefore for instance also the RF output of a navigation payload (coupled out from before the navigation antenna) could be connected to the system for payload performance testing.



Figure 3 Navigation antennas with omni-directional pattern on EADS-Astrium building

RF-Frontend

Each of both systems is equipped with six wide-band RF front-ends for the different navigation signals mainly of Galileo and modernized GPS, with centre-frequencies and bandwidth shown in Table 1. The front-ends amplify and down-convert the signals in two steps (according to the super-heterodyne principle) to a common IF-frequency of 71.61 MHz for all frequency bands. A frequency generation sub-unit generates all correspondingly required LO-frequencies from a common 10 MHz internal Rubidium-oscillator or an externally applied stable frequency standard.

Band	Centre-Frequency [MHz]	BaySEF 3-dB-Bandwidth [MHz]
E5	1191.795	100
E5a	1176.45	53
E5b	1207.14	54
L2	1227.60	54
E6	1278.75	54
L1	1575.42	54

Table 1 Front-end frequency-bands and bandwidth

Additionally also the DDC sampling clock of 460 MHz is generated here. The IF-output-power of about -3 dBm is kept constant with an AGC-loop. Phase- and amplitude distortions of the front-end can be compensated with an equalisation filter in the digital section (see DDC-description). Even if all six frontends are operated simultaneously, only four frequency bands can be further processed with one BaySEF measurement-system-rack in parallel. Therefore the front-end also houses a so-called ‘switch-matrix’ to allow computer-controlled selection of an arbitrary combination of four frequency bands.

DDC

Each of the selected up to four analogue IF-signals is sampled and pre-processed with an individual digital down-converter (DDC). The pre-processing functions are

- (IF-) complex carrier multiplication,
- low-pass-FIR-filtering including decimation,
- complex-FIR-filtering for wide-band amplitude and phase equalisation (of the RF-frontend characteristics),
- optional down-quantisation and
- output formatting for the front-panel-data-bus (FPDP) interface.

The 8-bit ADC has an analogue input-bandwidth of about 1 – 150 MHz and is operated with 460 MHz sample-rate, which was selected for overall minimum spurious-levels.

One special feature of our system is the high flexibility of the pre-processing due to widely adjustable parameter settings. Beside a conventional flexible NCO setting capability especially the filters coefficients are freely adjustable. Therefore, the decimation-filter allows the decimation-factor DEC to be selected to any integer value in-between 2 and 275, with corresponding FIR filter-length of $24 \times \text{DEC}$. By this, the bandwidth can be adjusted from maximum RF-bandwidth down to very-narrow bandwidth with well adapted reduced data-rate. Also the 60-tab complex equalisation filter is of course user configurable.

All DDCs can be operated with synchronized sampling and decimation independent time-synchronized output data-streams, allowing sample-synchronized navigation processing including cross-frequency combined processing (like required traditionally for real-time semi-codeless P(Y)-code tracking for instance).

Each DDC output-stream consisting of these base-band signal samples is distributed to a data-recorder

and in parallel as input for GPS/Galileo real-time-receivers.

Data-Recorder

The data-recorder has a maximum recording rate of at least 120 MByte/s, which is adequate for full bandwidth E5-signal recording with 4-bit resolution, and for the other frequency bands even with 8-bit resolution. The recording capacity allows for continuous measurement periods of at least 80 minutes (with maximum rate/bandwidth and resolution) on all four channels simultaneously. For the future, this recording capacity could even be increased considerably, if required. The recorded signal files can be either used for repeated playback to the GPS/Galileo real-time-receivers or readback via Ethernet or Fibre-Channel to PCs for offline processing. Even in multi-frequency-band ‘real-time’ playback-mode, the inter-frequency-band synchronisation can be maintained.

RTR-Receivers

If obtained direct from the DDC-outputs or in playback-mode from the data-recorders, the FPGA based navigation receivers make no difference in processing of these base-band data-streams in real-time. Both measurement systems include four receivers (one per selected frequency band) that are flexibly configurable with respect to all open Galileo and GPS signals as well as many tracking parameters. Each receiver allows parallel processing of up to 12 satellite-signals using up to five correlators of adjustable delay. A major task splitting within the FPGA is performed between GNSS-core and LEON-processor. The GNSS-core performs the input-pre-processing, reference-signal generation, correlation and carrier-multiplication including corresponding NCO and delay-lines functionality. Optionally also a pulsed interference detection and blanking is envisaged. This processing in the GNSS-core is widely configurable per initialisation-settings for instance with respect to pre-filtering, code-generation, sub-carrier parameters, correlation delays, correlation periods, etc. The computationally more complex but ‘lower rate’-operations are performed in the LEON-processor. This includes the loop-closures (like discriminator-evaluation, loop-filter and NCO update computations), but also tasks like channel-management and time handling. As this part is even more software oriented, flexible adjustment of discriminators, tracking modes (e.g. the combination of pilot- and data-channels or AltBOC) and loop-filter parameters is possible. Additionally to the FPGA implemented processing, a high level navigation software for channel planning and PVT-computation is running within the M&C-PC. The real-time Galileo/GPS receivers are able to process the full bandwidth signals for all bands, despite for AltBOC-E5, where minor processing bandwidth-limitations exist.

GPS-Reference-Receivers

For reference, comparison, validation and development support, each of both BaySEF measurement system is completed with a commercial Novatel DL-4plus RT2W GPS receiver, which is fed with the signals from the BaySEF antennas (see also Figure 1). This receiver is of high performance and accuracy with the possibility of fast data update rates.

M&C

The management of the full measurement system is performed with a dedicated M&C-software, operated on a conventional Linux-PC. This software communicates with all sub-devices (via different interface types) for

- initialisation and parameter-setting,
- start and end of synchronized measurements (and playbacks),
- device control,
- data acquisition and storage from navigation receivers.

It provides a user-friendly access to full BaySEF flexibility with graphical user interfaces for

- measurement and monitoring parameter selection
- display of relevant log-information
- quick signal monitoring.

An example of the main GUI-window for parameter-settings is shown in Figure 4.

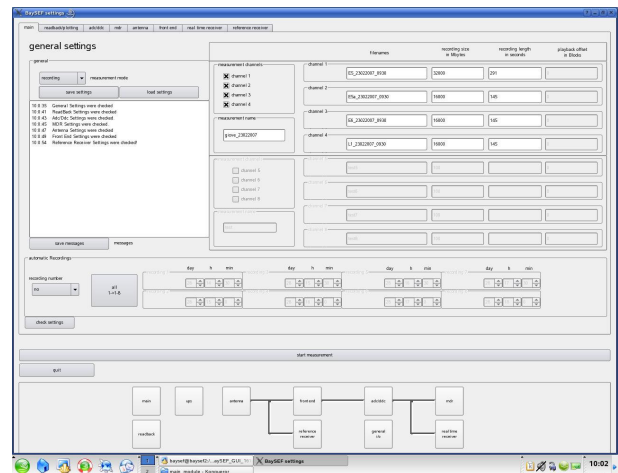

Figure 4 GUI example window for parameter settings

OFFLINE PROCESSING AND EVALUATION

Additionally, the recorded signals can also be offline processed with pure software receiver algorithms, written in C-programming language and running on Linux-PCs. All this is denoted as ‘offline navigation processing facility’ (ONPF) within the BaySEF. As real-time capability is not required for the offline processing, the optimisation of computation time is of less importance here and the effort is focused on the flexible implementation of processing algorithms adapted to the actual question of interest. As an example, in

addition to different tracking loop algorithms also the correlation function can be extracted with arbitrary fine resolution during tracking.

Moreover, this offline software platform is best appropriate for detailed analysis on transmit signal performance, to assess alternative algorithms for instance on signal tracking combinations, interference mitigation, false lock or cycle slip mitigation, multipath mitigation etc.

As the BaySEF focuses mainly on signal performance related questions, main output parameters of interest from the GPS/Galileo real-time receivers and the offline processing are the navigation raw data as C/N, code-phase, carrier-phase and the (de-)coded navigation symbol stream. But note again, depending on the question of investigation, the offline processing software may also be easily extended for more general signal sample analysis.

The results from different measurements and/or processing's are further analysed within the so-called 'evaluation facility' (EF). This is mainly a continuously growing Matlab tool-set for performance evaluation, simulation and comparison. In addition to simple statistical evaluations and presentation possibilities, also detailed realistic models for theoretical signal performance predictions are included, based on EADS-Astrium owned simulation tools. This enables a very detailed validation and assessment of tracking results.

Potential Applications

The BaySEF intends to contribute mainly to signal performance monitoring and the support of application design. The question is, how can this be reached with the BaySEF features as shown in preceding chapters ?

In fact, the intended BaySEF applications are based on the concept to process the same signal samples repeatedly with various processing parameter settings. Moreover, the processing focuses on signal-tracking of individual satellites rather than on PVT or RTK algorithms.

From comparison of the different results and from comparison with theoretical expectations, conclusions on the question of interest will be finally derived. A first typical example is the extraction of different UERE contributions of an individual satellite signal, like receiver noise, multipath, interference, ionospheric delay etc. For a set of processings with properly selected different receiver parameters e.g. for receiver-bandwidth, code-discriminator, interference mitigation, different frequency bands etc. and the comparison with simulation results based on pure receiver noise assumptions will finally allow the error separation.

Secondly and probably even more tailored to the BaySEF is the identification of optimized receiver parameters as support to application design, characterized for instance by certain receiver environments and desired accuracy or reliability levels. Corresponding signal samples could be obtained from wide-band recording during movement through typical environments. With

different processing-parameters and evaluation of the performance parameters of interest, the best appropriate receiver tracking parameters could be derived.

A next application example could be linked to the recording of signal-samples under bad boundary conditions like bad atmospheric conditions (like with strong scintillations or during solar storms) or strong multipath conditions (e.g. indoor) or strong interference (e.g. close to airports). The investigation would be again to identify the optimum method to mitigate corresponding distortions during tracking.

The wide-band RF-frontend and recording allows also evaluating transmission characteristics and details of the signal. This can be done partly by the analysis of fine-resolution correlation-function and partly also by signal-sample-analysis like from sample-oscilloscope measurements (but from much longer periods) acquired from a high-gain antenna.

For detailed assessments like on frequency dependent phase- and amplitude distortions also an accurately calibrated measurement system is required. When deriving from the correlation-function shape care must be taken, that no relevant interference or multipath distortion degrades the measured signal.

Finally the BaySEF can be used for realistic signal performance analysis when fed with new signals (like MBOC) from corresponding signal generators, before corresponding receivers are available. And the flexible selection of receiver parameters enables analysis beyond a single fixed receiver architecture.

To summarize the BaySEF is especially appropriate for investigations which require

- wide-band signal acquisition from various interfaces
- recorded signal samples and
- repeated processing of different, in a wide range adjustable receiver parameter settings focussing on tracking of individual satellites.

Example Evaluation Results

Currently the BaySEF is still in an integration-phase. Nevertheless, the measurement system and a first version of the offline navigation processing software are already in operation, demonstrating promising results. As a first example, fine-resolution normalized correlation-functions for L1 GPS C/A-code and GIOVE-A are shown in Figure 5. These correlation-functions are evaluated from a BaySEF measurement in L1-band at EADS-Astrium Ottobrunn promises with 46 MHz bandwidth, recorded at 31th January 2007. For noise-reduction, the correlation functions have been averaged coherently for a period of about 30 seconds during tracking.

In this example, the evaluated range has been intentionally extended beyond +/- one chip to show also measured non-ideal code-behaviour.

Therefore, also theoretical ideal correlation functions (without band-limitation) are overlaid, accounting for

the full code-auto-correlation properties and for GIOVE also for the cross-correlation between L1-B- and L1-C-channel codes, assuming equal data- and/or secondary-code modulations.

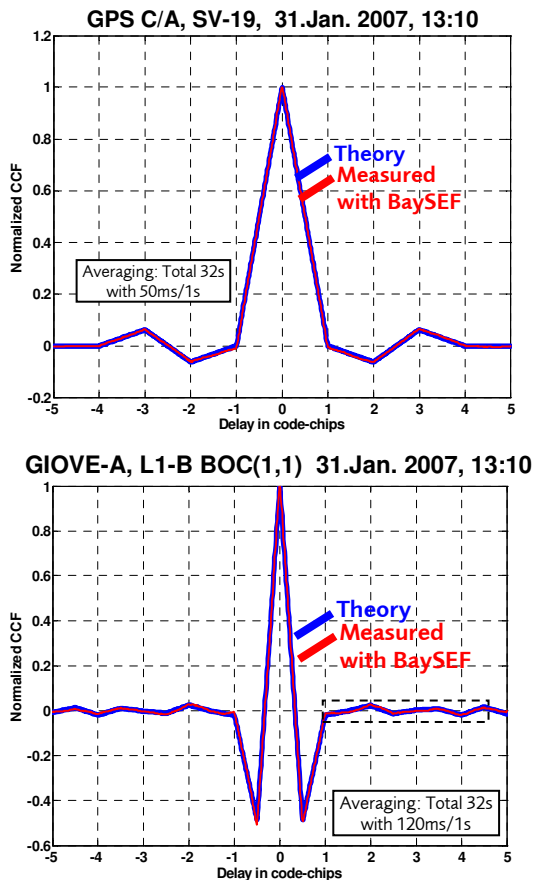

Figure 5 Examples for measured fine-resolution normalized correlation functions of GPS C/A and GIOVE L1-B.

For both GPS C/A and GIOVE, theory and BaySEF measurement fits very well down to a relative amplitude accuracy in the order of better 15 to 20 dBc. Nevertheless even deviations below this level impacts for instance the tracking performance as is shown with the second type of example evaluations.

In Figure 7, the measured code-jitter for corresponding GIOVE-signals is shown for non-coherent power-discriminator in dependency of early-late-spacing down to very narrow values (0.01 chips) in comparison with some theoretical evaluations. Note, the high absolute jitter is not due to bad tracking algorithms or receiver performance but due to the selected high loop-bandwidth of 20 Hz. The high loop-bandwidth was selected to enable short processing periods providing sufficient statistically independent samples for noise-jitter evaluation and avoiding simultaneously static multipath to affect the results. Note the jitter was evaluated from the pseudo-range results with a best fit third order polynomial subtracted. For typical 1 Hz single-sided loop-bandwidth all noise-jitter contributions would be divided by a factor of 4,5, but measurement results would be degraded also more by multipath (as for statistical jitter evaluation a correspond-

ingly 20-times longer tracking period would be required).

The measurement results show improving code-jitter with narrowing the correlator-spacing despite for very low early-late-spacings. For early-late-spacings below about 0.03 chips tracking jitter starts to degrade again. That's it what we can conclude without additional theoretical analysis. Now let us add theory. The red curve in Figure 7 is for an ideal infinite bandwidth correlation function and the measured C/N as derived with the EADS Astrium simulation-tool 'GalSigGen' and based on analytical noise-jitter-equations given in [1]. It's quite close to the measurement results but with two main differences. First it predicts slightly worse noise-jitter than measured (for early-late spacings above 0.02 chips) and secondly it improves monotonically even for very low early-late-spacings. We guess, these deviations may be due to band-limitation. Therefore we took into account the BaySEF transfer characteristic including also its amplitude and phase-distortions in a next step of theoretical comparison. Now the theoretical expectations generally fit much better including the trend-inversion for very low early-late-spacings.

The fit has been further improved by assuming additional payload band-limitation to 40 MHz. Nevertheless some deviations remain, which are probably due to interference, residual multipath and payload distortions. Corresponding separation would need a very careful and rigorous analysis which was beyond the objectives of initial BaySEF experimentations.

In anyway this example demonstrates the potential of BaySEF measurements especially when combined with theoretical analysis.

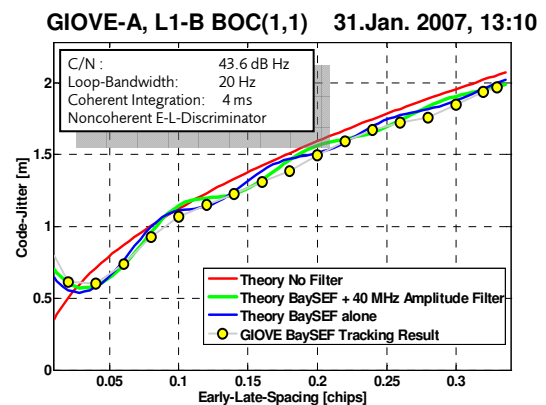

Figure 6 Examples for measured code-jitter in dependency of early-late-spacing of GIOVE L1-B together with theoretical expectations.

When doing the same analysis for GPS C/A SV-19, quite different results were obtained as shown in Figure 7. For low early-late spacings (below 0.15 chips), theory and measurement results fit well as for GIOVE. But for wider early-late spacing the measured code-jitter becomes more and more degraded against theoretical predictions. (up to about 30 percent at 0.7 chips early-late-spacing). Up to now, this has not been

analysed more quantitatively but it is assumed this is due to narrow-band interference around the L1-center frequency, which is not taken into account within our theory. Within [2] it is shown, that indeed such degradation effects are expected from narrow-band interference.

Even if derived from the same period, the GIOVE-tracking processing results are not much affected by this interference, as the spectral shape of the BOC(1,1) is quite insensitive against these L1-centre interference.

As a summary, already these first BaySEF evaluations demonstrate its high potential for high quality signal performance evaluations. More evaluation examples e.g. on other GIOVE-signals are discussed in [3].

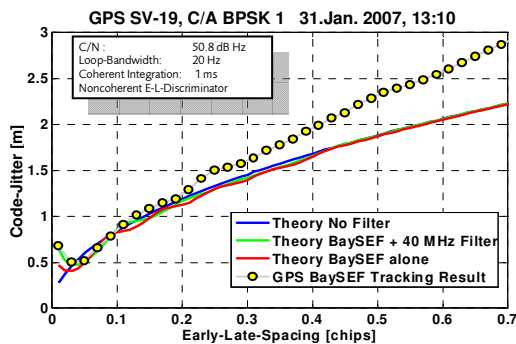

Figure 7 Examples for measured code-jitter in dependency of early-late-spacing of GPS C/A SV-19.

SUMMARY AND CONCLUSION

In this paper, the architecture of the BayNavTech Signal Experimentation Facility is explained. Potential applications in the field of signal performance monitoring and support to application design are sketched, which take especial advantage of key features as summarized in Table 2.

Two identical measurement systems (one stationary and one extension/mobile)

Various signal interfaces (omni-antennas, 3m dish, RF/IF-signal-generators)

Each measurement-system for simultaneous signal acquisition and processing of four frequency-bands out of E5, E5a, E5b, L2, E6 and L1

Wide-band frequency-channels: E5 > 100 MHz, E5a, E5b, L2, E6 and L1 > 50 MHz

Base-band sample-recording up to 120 MByte/s per frequency-band (→ full bandwidth recording)

Optional digital band-limitation to any bandwidth and adapted decimation

Flexible GPS/Galileo receivers also with capability to process recorded samples

Offline navigation processing PC-software of recorded samples allows investigation based adaptation of used algorithms

Synchronized processing, external/internal reference, accurate calibration and many more features...

Table 2 BaySEF Key Features.

The BaySEF development is not finalized but will be continued at least until the end of this year and may be further adapted for future applications.

Main near-term tasks are the integration and testing of the real-time-receivers as well as the accurate calibration of the BaySEF transfer-distortions. Also the off-line-navigation processing software will be further extended for instance to cover additional signals and tracking modes.

In parallel to this work it is also intended to use the BaySEF as much as possible for measurement campaigns.

First operations of the BaySEF have demonstrated full functionality and performance of the frontend and recording system. Example evaluations shown in this paper revealed very interesting results opening a wide field of potential future in-depth investigations. Therefore the BaySEF is ready to be used also for co-operations with you and your investigations of interest.

ACKNOWLEDGEMENTS

BaySEF is part of BayNavTech™ program, which is supported by the Bavarian Government (Ministry for Economic Affairs, Infrastructure, Transport and Technology).

REFERENCES

- [1] M. Soellner, Ph. Erhard, 'Comparison of AWGN Code Tracking Accuracy for Alternative-BOC, Complex-LOC and Complex-BOC Modulation Options in GALILEO E5-Band', GNSS 2003, Graz
- [2] F. Soualle, 'Introduction of an Additional Radio Frequency Compatibility Criterion for Code Tracking Performance', 2nd Workshop on GNSS Signals & Signal Processing – ESTEC – 24-25 April 2007
- [3] M. Kaindl, M. Soellner, C. Zecha, R.Kohl, 'Performance comparison between Giove-A signals and GPS based on wideband measurements with the BayNavTech™ Signal Evaluation Facility (BaySEF™)', ENC-GNSS 2007, Geneva

ABBREVIATIONS

AGC	Automatic Gain Control
DDC	Digital Down-Converter
LEON	Synthesizable VHDL model of a 32-bit processor
LNA	Low Noise Amplifier
MBOC	Multiplexed Binary Offset Coding
NCO	Numerically Controlled Oscillator
ONPF	Offline Navigation Processing Facility
PVT	Position Velocity Time
RTK	Real-Time Kinematik
USERE	User Equivalent Range Error
UPS	Uninterrupted Power Supply