

# Navigation Competence and Technology in Munich

## The BayNavTech™ Satellite Navigation Centre Munich

... is the Centre of Navigation Competence and Technology at EADS SPACE in Ottobrunn. It brings together the satellite navigation expertise in the Munich area to form a European centre for satellite navigation systems, performance as well as applications and solutions.

It provides key services for:

- Performance verification and monitoring of satellite navigation signals, navigation systems and services,
- Provision of an analysis environment for the assessment of the performance and further development of satellite navigation systems,
- Development and verification of navigation signal generating and processing hard- and software, and
- Development, verification and monitoring of application systems and services as well as applications, which are based on positioning

and/or navigation information.

The BayNavTech Satellite Navigation Centre Munich consists of two core facilities:

- **BayNavTech™ Signal Evaluation Facility (BaySEF™)**, a flexible Software Receiver and Evaluation Platform for reception and processing of navigation signals and determination of the signals' performance parameters, and
- **BayNavTech™ Performance Assessment Facility (BayPAF™)**, a flexible development and analysis environment for the determination of the performance of system and application algorithms being used in navigation systems, application systems and services.

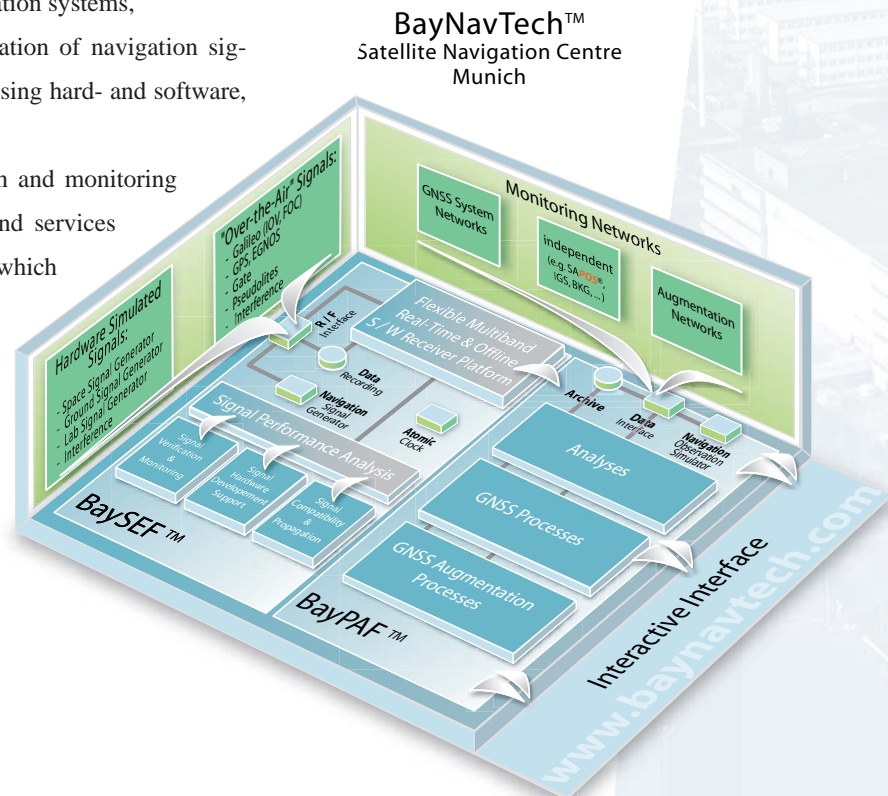

**The BayNavTech™ Satellite Navigation Centre Munich provides the following services** to developers, operators, value-added service providers and end users of satellite navigation and related applications and services.

- Performance Services including ...
  - ... routine operational performance monitoring of satellite navigation and augmentation systems
  - ... customised performance assessment and analyses
- Development Support Service providing ...
  - ... support of hard- and software development activities with simulations and analyses by implementation of new developments into the processing chains for related analyses
- Data Provision Services including ...
  - ... navigation message data,
  - ... high precision post-processed navigation data for reference purposes, e.g., precise post-processed orbits
  - ... navigation-related supplementary data, e.g., time synchronisation data, ionospheric data, intermediary performance figures, ...
  - ... GNSS monitoring data
  - ... navigation augmentation data, e.g., local integrity information
- Signal Compatibility Assessment Services, namely ...
  - ... assessment of signal compatibility with respect to special reception environments, e.g., multipath, interference, jamming, ...
  - ... laboratory as well as field experiments with transportable BayNavTech equipment

The functionalities of the BayNavTech Satellite Navigation Centre Munich refer to satellite navigation systems themselves, in the first place the European satellite navigation system Galileo but also to GPS and augmentation systems, which are, by means of improved accuracy, availability and integrity, the basis for numerous location-based applications.



Bildquelle: Leica Geosystems AG, Schweiz

# Analysing Navigation Signals and Performance

## The BayNavTech™ Signal Evaluation Facility (BaySEF™)

... is a flexible high-end reception, processing and evaluation platform for the analysis of navigation signals and their performance parameters. It is designed to meet the highly demanding requirements for navigation signal verification and covers all relevant signals, namely the European satellite navigation system Galileo, the US-American GPS, but also augmentation systems like EGNOS or Pseudolites.

The core of BaySEF is a highly flexible software receiver, which can be configured to provide a range of characteristics, from high performance receivers down to low-end mass market receivers.

Physically the BaySEF™ consists of two equal transportable receiver systems, each equipped with six front-ends to receive Galileo and GPS navigation signals in E5a, E5b, E5 (wideband), L2, E6, and L1. The RF bandwidth is 40 MHz for all front-ends except for 90 MHz for the E5-signal.

The signals from four out of the six relevant frequency bands can simultaneously:

- Be recorded for periods from 20 minutes up to a few hours, depending on the resolution, per front-end channel
- Be real-time processed by FPGA based receiver channels

in order to obtain raw data for the different satellite signals in view, namely Signal-to-Noise power ratio (C/No), code-phase, carrier-phase and the undecoded/decoded navigation symbol stream.

The recorded signals can be played back into the real-time receiver boards as well as processed offline with pure software receiver algorithms.

The navigation raw data obtained from different signals, satellites and processing parameters/methods can be evaluated statistically with respect to mean-value, drift and jitter and compared against each other focusing on the aspects of signal performance under investigation.

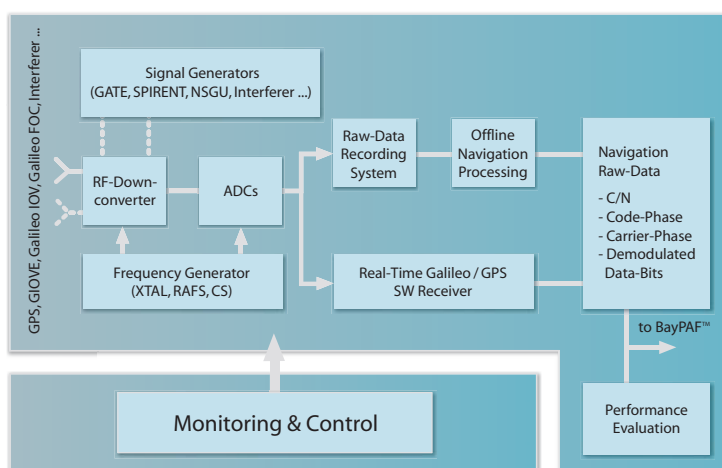

BaySEF™ Functional Architecture

BaySEF is a reference platform for the purposes of:

- Analysis and verification of navigation signals as part of system acceptance processes and as independent system signal performance monitor
  - ... assessing navigation signal link performance, e.g. signal-to-noise power ratio (C/No), ionospheric dispersive effects, receiver environment multi-path effects and interference degradations
  - ... determining signal performance parameters like code and carrier phase statistics, bit, symbol and frame error rates, and
  - ... providing full flexibility with respect to system requirements like type of input signal, multiplex/modulation, bandwidth, processing and discriminator types (e.g. type and order, loop bandwidth/integration time, correlator number & spacing).
- Signal support to Frequency Coordination activities
  - ... covering analysis of navigation intersystem (e.g. Galileo to GPS, GLONASS, QZSS, ...) signal performance degradations,
  - ... covering analysis of interference with co-frequency band users like Mobile Satellite Services, Wind Profiler Radar, Distance Measurement Equipment, Tactical Communication, Ultra-Wideband, and
  - ... providing a transportable reference receiver unit for the above tasks
- Test and verification of performance parameters of navigation system hardware elements, e.g., space-borne equipment like Navigation Signal Generator Units, Rubidium Atomic Frequency Standard and ground based equipment such as navigation

receivers and its components (antennas, front-ends, back-ends and S/W algorithms)

- Analysis and verification of effects of signal performance aspects on services and applications
  - ... focussing on augmentation, e.g. by pseudolites, differential reference networks
  - ... focussing on specific application environments, e.g., urban - and indoor applications
  - ... providing a transportable reference receiver unit for the above tasks

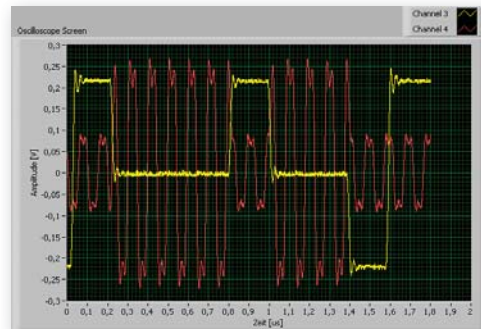

BaySEF™ Signal Analyses:  
GPS C/A Code - Office Processed Correlation Functions

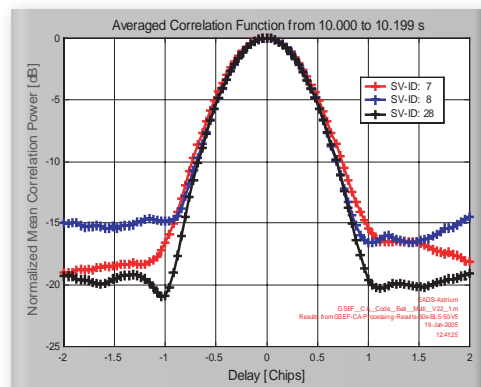

BaySEFF™ Galileo Signal Generator:  
Snapshot of E6-Band Baseband Output

# Analysing Navigation System Processes and Performances

## The BayNavTech™ Performance Assessment Facility (BayPAF™)

... is a highly configurable high performance Analysis Centre for satellite navigation systems and applications. It is designed to allow for the assessment of navigation and application system processes by determining figures of merit or comparison of processing results with BayPAF™ reference data.

The BayPAF is based on a process chain oriented approach controlled by user defined so-called Order Files. These configuration files are XML formatted and contain all the information necessary for processing and execution, such as identification of the modules to be executed within the chain, configuration parameters associated with modules, and input data identifiers.

The modular architecture additionally allows the implementation and execution of specially defined modules, so-called User Modules. These modules can be either modifications of original modules, e.g., to investigate new algorithms, or newly developed modules.

BayPAF processing chain modules provide:

- Data Simulation & Manipulation for generation of receiver raw observations with / without exactly defined error effects,
- Preprocessing
- Orbit Determination & Time Synchronisation (ODTS) and ODTS Figure of Merit calculation (Signal-in-Space-Accuracy SISA),
- Global Integrity, Local Integrity
- Analyses

For standard investigations and analyses a number of modules are grouped. For further investigations however the modules can be freely arranged by experienced users and processed by the system.

The hardware environment of the BayPAF consists of a set of workstations (based on PC architecture), which is scaleable and can be extended. The workstations are controlled by a highly redundant server and processing on these workstations can be performed in parallel.

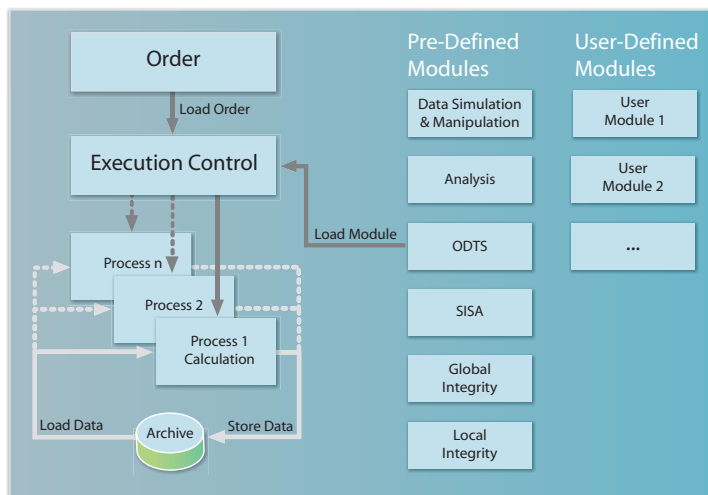

BayPAF™ Functional Architecture

The BayPAF is an analysis and reference platform for the purposes of

- Independent verification of satellite navigation systems:
  - ... Implementation of independent offline and near real-time high performance satellite navigation system processes including precise satellite orbits and time synchronisation (ODTS), global system integrity and local integrity
  - ... Monitoring and analysis of system algorithms performance parameters
  - ... Generation of user defined analyses and statistics (e.g. performance trends, error statistics).
  - ... Provision of robustness analyses, Feared Event analyses and tests.
- Interactive development, analysis, training and demonstration platform:
  - ... Development and test of new algorithms and models.
  - ... Interactive interface for demonstration and training purposes.
  - ... Available for universities, institutes, developers of applications, GNSS future generation development, ...
  - ... Web-based access
- Support of services and applications:
  - ... Provision of the technological basis for future services, e.g., verification of regional/local navigation signals or provision of local integrity for service providers.

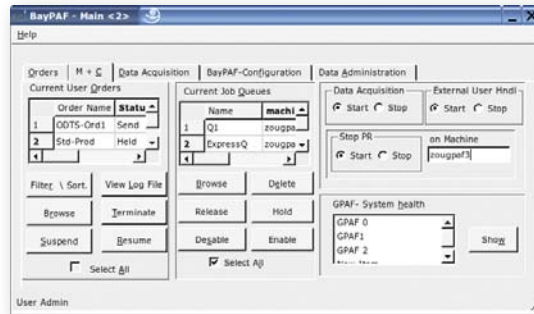

BaySEF™ Man Machine Interface



# Example 1: BayNavTech™ assessing navigation signal compatibility

## Measurement and analysis of potential interferences between GNSS signals and radar signals

Satellite-based radio navigation systems (RNSS) have to share the frequency spectrum allocated by the World Radiocommunication Conference 2000 in Istanbul (WRC 2000) amongst each other and with other existing radio services in the frequency bands. Compatibility of all transmitted radio signals is a mandatory pre-requisite for interference-free provisioning of the corresponding services.

The European RNSS satellite system Galileo transmits its so-called E6 spread spectrum RNSS signal over one of the allocated frequency bands from 1260-1300MHz with a centre frequency at 1278.750MHz. This band is to be shared with a variety of radar systems operating in the Radiolocation Service (RLS).

The most critical group of radars are the meteorological radars for wind profiling. They use upward-looking antennas to determine real-time wind speed, direction, and other physical characteristics in several distinct altitude layers between 500 and 4.000m. These Doppler-type radars operate with single frequency transmitters and receivers at the limit of technically achievable sensitivity, because the reflected signals are very weak.

BayNavTech™ performs a measurement campaign in December 2005 to determine the radio compatibility of Doppler Wind Profiler Radars and the E6 signal to be provided by the European Satellite Navigation System Galileo.



1290MHz Wind Profiler Radar (WPR) at the meteorological Observatory Lindenberg (MOL) of the German Weather Service (DWD) in Lindenberg, Germany

In December 2005, in a measurement campaign in co-operation with the German Weather Service (DWD), EADS Astrium under the observation of the German National Regulatory Authority (BNetzA), used the BayNavTech signal generator and other elements of the BaySEF to generate the representative E6-signal and analyse the compatibility performance with the wind profiler radar signals.

A CEPT ECC-Report documents the results proving the compatibility of E6 (RNSS) and the Wind Profiler Radars (RLS).

# Example 2: BayNavTech™ ensuring precision for satellite navigation and its application

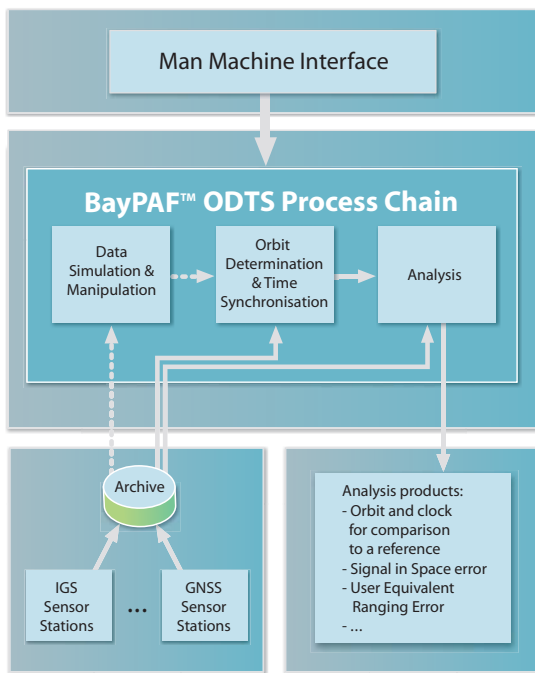

## Determination of precise orbital and clock data for GNSS satellites

The broadcast GNSS navigation messages shall be analysed with respect to accuracy and performance of the broadcast satellite orbits and clocks.

For this purpose the BayPAF shall calculate precise satellite orbits and clocks for the GNSS constellation and analyse the system algorithms implemented in GNSS ground segments contributing to the generation of navigation messages.

The BayPAF ODTS module is calculating precise satellite orbits and time synchronisation. As for different analyses and users a trade-off is to be performed with respect to accuracy, calculation time and latency, different products are generated by the BayPAF.

By comparing the generated precise orbits and clocks with the GNSS navigation message, the performance of the GNSS system's ODTS system algorithms can be analysed.

The figure below shows a comparison of the BayPAF near real time orbit accuracy (Ast) with all agencies contributing to the International Geodetic Service (IGS) Ultra Rapid Orbit product (please consider that IGS rapid orbits have a latency of three hours and are updated four times a day only).

BayNavTech™ provides high-precision ODTS products for satellite navigation constellations:

ODTS Product	Product Attributes	
Near Real-time Orbit	Latency:	1h
	Calculation time:	60-90 min
Predicted Orbit	Latency:	1h
	Calculation time:	30-45 min
	Prediction time:	3-24 h
Final Orbit	Latency:	< 2 days
	Calculation Time:	2 h

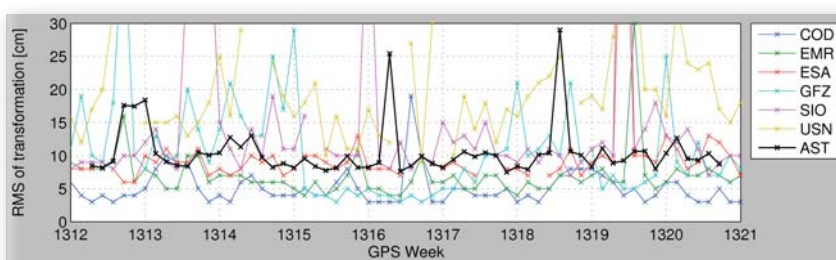

# Example 3: BayNavTech™ guaranteeing satellite navigation performance for applications

## Support Verification and Certification of GNSS-based Applications, Services and related Equipment

Considering the requirements of high-end professional GNSS-based applications with respect to reliability, performance and potentially service guarantees, a need arises for accreditation of hard- and software receiving, processing and displaying the related data. Consequently, the issue of standardisation and certification becomes very important for the respective user communities and service and solution providers as well as the successful market acceptance of satellite navigation based solutions.

The capabilities of the BayNavTech core facilities with respect to

- Simulation
- Performance assessment and analyses,
- Generation of reference data, and
- Statistical analyses

allow for the execution of the technical assessment and verification required for the generation of technical reports as input into certification processes.

BayNavTech™ contributes

... to the verification and certification of applications based on satellite navigation systems and data

... to the development, verification and certification of equipment for the provision and access to applications and services based on satellite navigation

by conducting the required technical performance assessments within a high-precision reference environment.

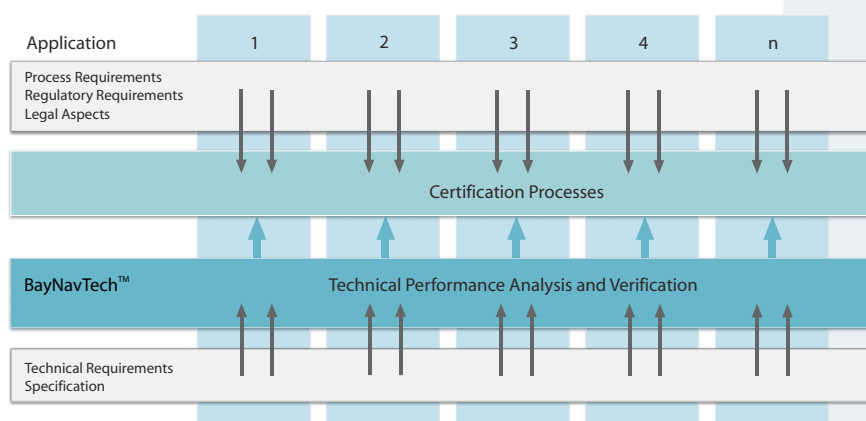





# Serving a Broad User Community

---

## The BayNavTech™ Satellite Navigation Centre Munich

... serves a broad user community, which relies on GNSS to provide value-added services:

### GNSS Programmes' Key Players

... for key tasks in system design, development and verification

### GNSS Operators and Concessionaires

... for verification, validation and (operational) monitoring

### Application, Solution and Service Providers

... for development, optimisation, performance assessment, verification purposes

### Navigation Hardware and Infrastructure Manufacturers

... by contributions to verification of, e.g., receivers and signal generators

### Standardisation and Certification Bodies

... by provision of GNSS performance and reference data

### Research and Development Community and Institutions

... e.g. universities, research institutes, R&D departments

### Educational and Training Institutions

... for demonstration and as training platform

### **We also serve Your Business**

... by customised support and solutions optimised to meet your needs and requirements

**CONTACT US!**



## BayNavTech™ Satellite Navigation Centre Munich

BayNavTech™ Performance Assessment Facility (BayPAF™)  
BayNavTech™ Signal Evaluation Facility (BaySEF™)

baynavtech-info@astrium.eads.net  
www.baynavtech.com



**EADS SPACE**  
Ludwig-Bölkow-Allee  
81663 Munich / Germany



EADS SPACE's BayNavTech™ Programme is supported and co-funded by the  
Bavarian Ministry of Economic Affairs, Infrastructure, Transport and Technology.